

MAURER S-Car Coaster



MAURER SÖHNE
forces in motion



Since 1876

Maurer S-Car – pure riding enjoyment

Seat Design

Our **Spinning Cars** seat four persons and travel through the track as independent units. A pivot bearing between the passenger car and the undercarriage converts the centrifugal forces generated in curves into rotational movement. The four passengers sit back to back, separated by a bucket seat which prevents exposure to uncomfortable levels of stress during the turns. Looking outward from the centre of rotation over the front panel of the car gives passengers that extra kick – you won't find a more direct or intense coaster experience anywhere!

Diversity on every ride

Each Spinning Coaster ride is entirely different from the one before: The movements of the cars always depend on the distribution of passenger weight and the course of the track, making every ride a whole new adventure. The ride configurations are determined by the random movement of the car forward, backward or even sideways, guaranteeing an ever-changing adventure no matter how many times a passenger takes a ride. The unrivalled centrifugal brake assures that the fun remains safe and the rotational speed pleasant.

Pure dynamic motion in a 360° carousel. The S-Car's high-quality undercarriage is designed for maximum twisting and bending.





Versatile and reliable

Theming

The coaster is ideally suited for adaptation to a theme. In addition to the many opportunities for integrating the ride in the specific theme of a park area, the S-Car also offers a wide variety of possibilities for theme-based customizing. We turn your ideas into reality and will be happy to implement your special wishes.

High quality

The design, structural calculations and manufacture of the S-Car are subject to the strict EN standards and have undergone rigid safety inspection from the German technical inspector TÜV Süddeutschland. The outstanding safety technology offers optimal protection. We regard the use of a multiple redundant safety system as matter of course. The product's exceptionally high development and production standards have merged to yield an outstanding design that will fulfill the quality requirements of any park. The resulting reliability assures smooth operation and low maintenance.

Maurer S-Car – special effects

Add some extra thrill...

Maurer features unique mechanical special effects that take the passengers totally by surprise: The car stops suddenly and seconds later unexpectedly moves on to a new position, from where the ride continues in a different direction, barely giving passengers time to realize what is happening. For the Phantasieland amusement park in Germany different movements in the cars longitudinal and transverse axes were integrated in the theming of the ride.

Hinged Track

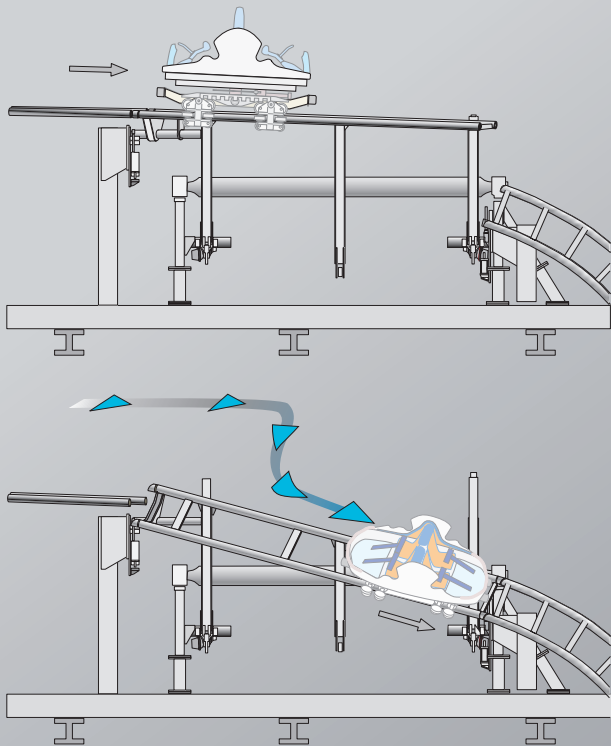

Vertical Express Lift

Starting at a shared loading platform, the four-person coasters are being catapulted more than 17 m (56 ft) upwards in a matter of seconds by a vertical express lift. Once at the top, there's no time for the passengers to catch their breath: Instead, their cars are sharply tilted downwards and the first drop suddenly appears.

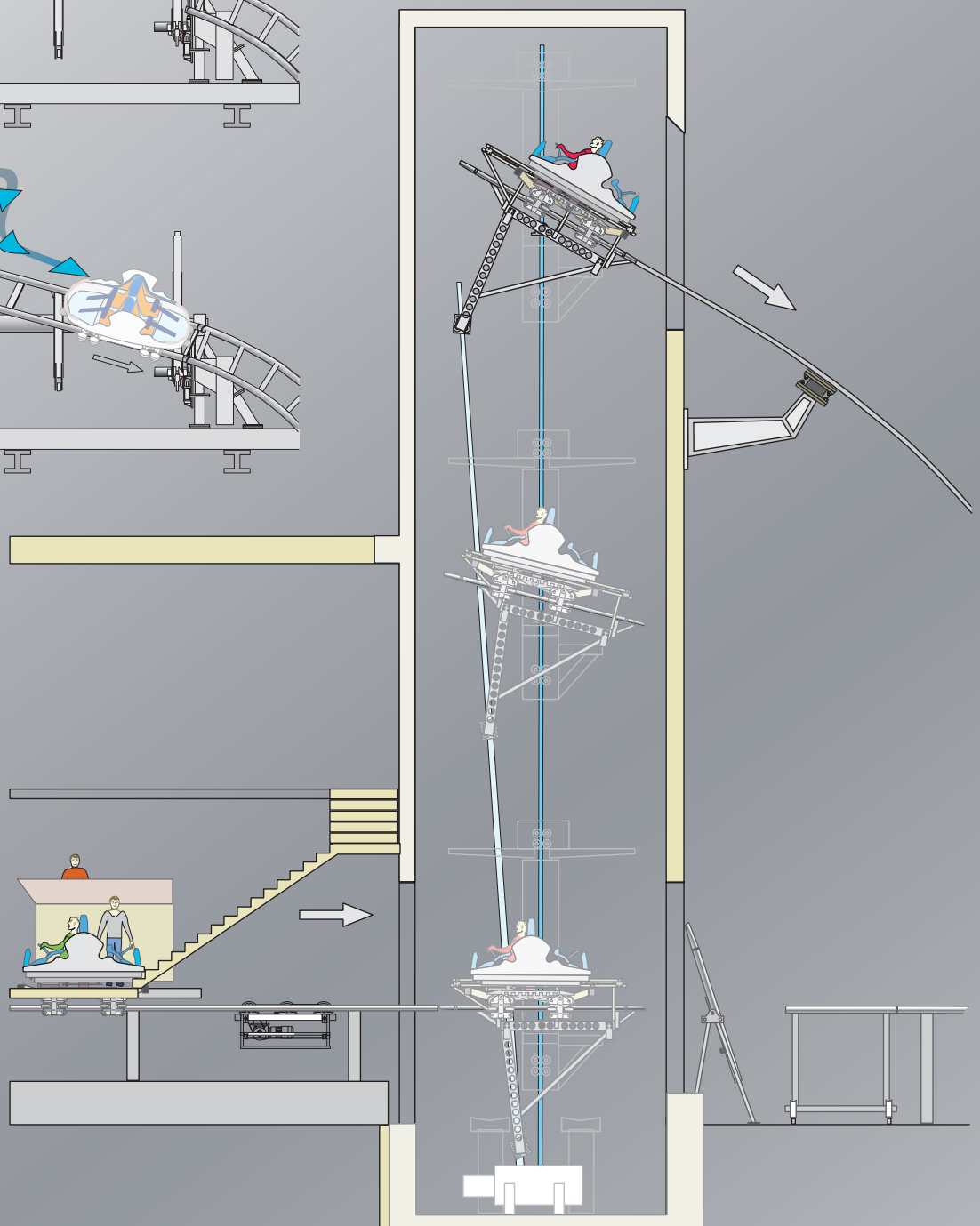

Drop Track

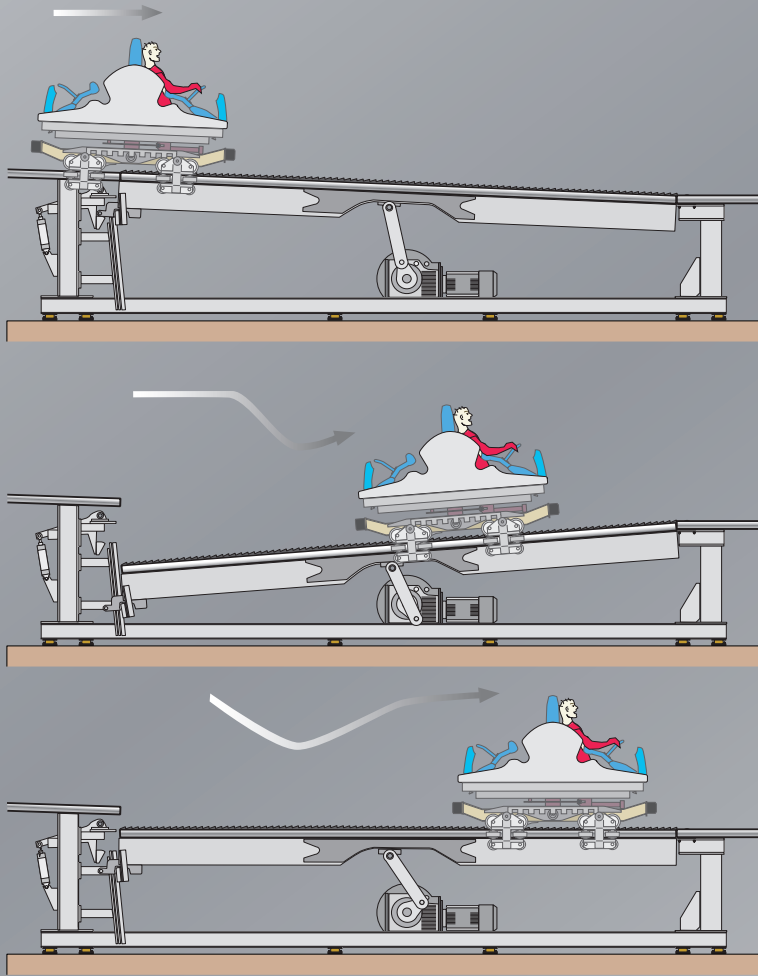

Seesaw

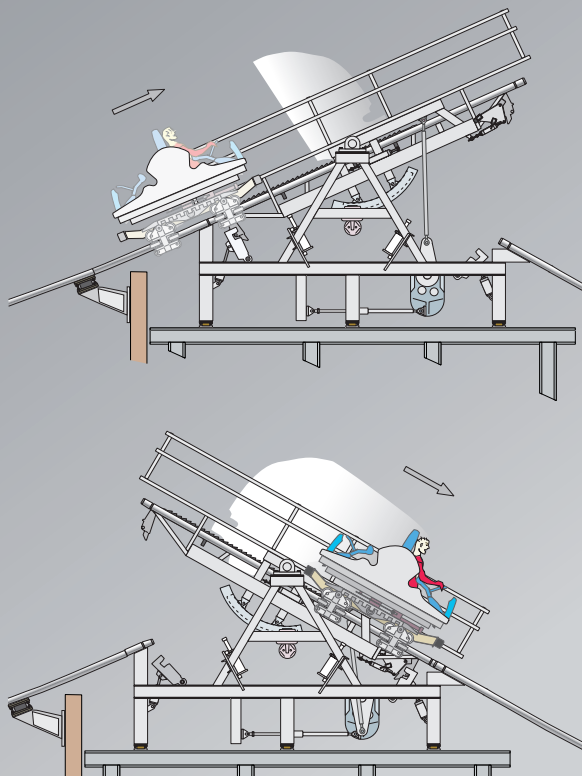

Tracks – standard

Standard SC 1000 / 2000 / 2200

The 3 standard track layouts all feature Maurer's astonishing S-Car and meet different requirements in size and capacity. Despite their compact construction, the SC 1000, 2000 and 2200 offer an unforgettable experience usually found only on significantly larger coasters. Another benefit: These high-banked turns, twists and many special effects can all be installed without foundations.

Spinning Coaster SC 2000 "Spider", Lagoon/USA





Technical Data **SC 1000**

Track length	240 m (787 ft.)
Height	9 m (30 ft.)
Number of cars	4
Capacity	600 pph
Base area	20 x 33 m (66 x 108 ft.)
vmax	43 km/h (27 mph)

Technical Data **SC 2000**

Track length	430 m (1410 ft.)
Height	15,5 m (51 ft)
Number of cars	8
Capacity	900 pph
Base area	23 x 45 m (76 x 148 ft.)
vmax	60 km/h (38 mph)

Technical Data **SC 2200**

Track length	450 m (1476 ft.)
Height	17 m (56 ft.)
Number of cars	8
Capacity	900 pph
Base area	55 x 62 m (180 x 203 ft.)

Tracks – custom built

SC 3000 – the custom coaster

The SC 3000 takes spinning coasters on to the next level – custom-designed layouts allow us to create coasters that are optimally adapted to the requirements and needs of any amusement park, thus building ultra-dynamic and attractive tracks full of surprising new features.

Example: Spinning Coaster SC 3000 "Tarantula", Parque de Atracciones/Spain





Data (Example) **SC 3000**

Track length	630 m (2066 ft.)
Height	25.5 m (84 ft.)
Number of cars	8
Capacity	870 pph
Base area	92 x 58 m (302 x 190 ft.)

Tracks – custom built indoor

SC 3000 – indoor

The 2 coasters “Winjas” in Phantasialand give a glimpse of the possibilities offered by the SC 3000: With a maximum speed of 70 km/h (44 mph), up to 1440 passengers per hour pass through 2 tracks equipped with vertical express lifts rising 17 m (56 ft.). But even these figures can merely describe the astonishing experience generated by the full interaction of theme and roller coaster. Guaranteeing an extremely quiet and smooth ride Maurer’s S-Car is ideal for indoor locations.

Spinning Coaster SC 3000 “Winjas”, Phantasialand, Germany





Theming: full integration at "Winjas"

- Full integration into theming possible
- Great entertainment even with limited space
- Practical high capacities
- Nearly endless configuration possibilities
- Reliability

S-Car

- Unique riding enjoyment thanks to sensational coaster dynamics
- Entertainment for the whole family and all age groups
- High-speed sensation with fantastic visibility
- Extremely compact layouts possible
- Endless theming possibilities
- Quiet ride due to noiseless anti-rollback system
- TÜV-tested safety concepts with multiple redundant safety systems
- Exceptionally high-quality standards
- Highly attractive and economical ride



Technical Data **S-Car**

Maximum acceleration	
Vertical positive	3.6 g
Vertical negative	0.0 g
Lateral	1.8 g
Longitudinal	-1.5 g

Top speed 80 km/h (50 mph)

Min. body height for children 120 cm (47")
Under parents' attendance 107 cm (42")

Certification TÜV Süddeutschland



S-Car is a trademark of Maurer Söhne; photos: Maurer Söhne, coastersandmore



Maurer Rides GmbH

Frankfurter Ring 193
80807 Munich/Germany
Phone: +49/89/3 23 94 - 221

Fax: +49/89/3 23 94 - 355
E-mail: ar@maurer-soehne.de
Internet: www.maurer-soehne.de

Maurer Rides USA, Inc.

Mr. Steve Boney
9402 Palm Tree Drive
Windermere, FL 34786

Phone: +1 407.923.9027
E-mail: boney@maurer-soehne.de